

FORD's REVERSE POLARITY TRUNK POP

DIAGRAM: Using a (-)NEGATIVE Trunk Pop Output

Requires (1) of part # 775

Connect the WHITE and the YELLOW wire from the #775 relay to 12 volts CONSTANT fused at 10amps.

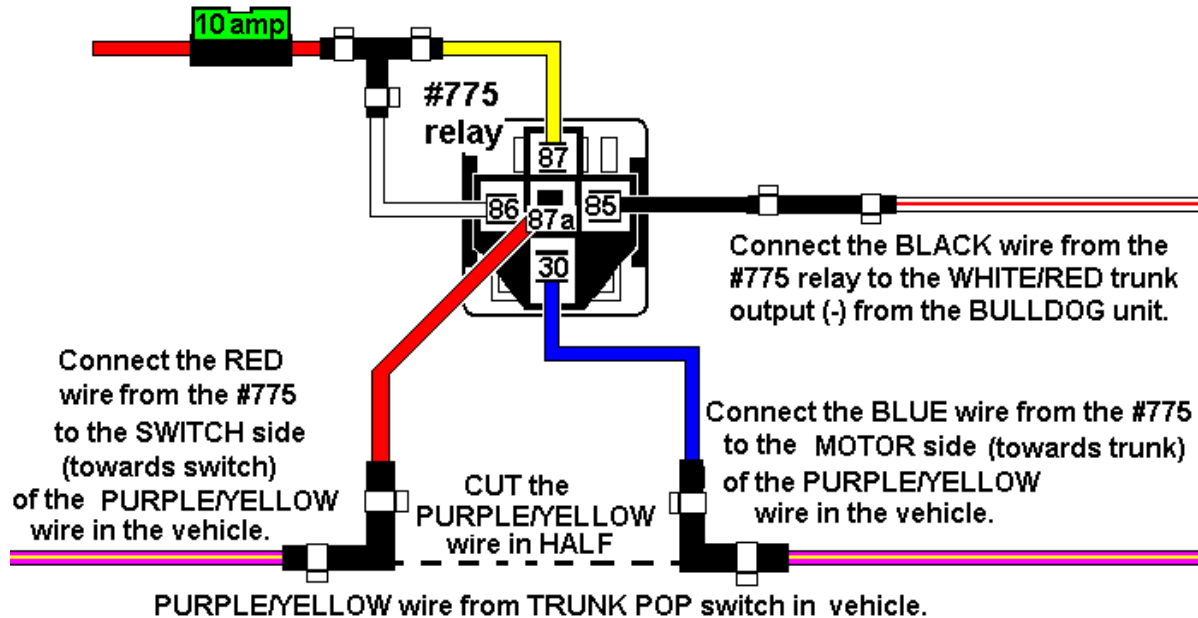

Using a (+) POSITIVE Trunk Pop Output: RS-1100(114),1200, and 1300E

Requires (1) of part # 775

