

INSTALLATION GUIDE

•

OWNER'S GUIDE

ALARM AND REMOTE CONTROL STARTER MODEL RS1300E

CONTENTS

System Features	1
System Components	1
Required Tools	1
Technical Assistance.....	2
Before You Begin.....	2
Precautions	2
Using your Test Probe.....	3
Making Connections.....	3-4
Locating & Making Connections	4-6
Neutral Safety Switch.....	6-7
Connecting Wiring Harness.....	7
Antenna Placement	7
Optional Connections.....	7-9
Operator Programming Instructions.....	9-10
How to use Your Remote Transmitter.....	10



Technical Assistance

All tech personnel are expertly qualified to answer any technical questions.
Technicians are available Monday through Friday from 9:00 a.m. until 8:00 p.m. and Saturday 10:00 a.m. until 4:00 p.m.

Address

288 Canton Avenue • Wintersville, Ohio 43953

Telephone

Phone: 740-264-4710 • 800-878-8007 • Fax: 740-264-7306

SYSTEM FEATURES

2 Four-Button Extended Range Remote Controls	Remotely start your car to run the heater, air conditioning or defroster from an extended distance.
Keyless Entry	Remotely locks and unlocks your power door locks.
Built In Alarm Features	Provides door, hood and impact protection.
Horn and Siren Output	Lets you choose between the vehicle's factory horn or an optional six tone siren.
Starter Immobilizer	When the alarm is armed, this option breaks the starter wire in half so the vehicle cannot be hotwired.
Door Trigger Protection	Provides protection when doors are opened.
Shock Sensor Input	Provides an additional input so an external sensor can be added to provide extra protection.
Trunk Release/Sliding Door	Remotely open your power trunk or your power sliding van door with a push of a button.
Remote Programmable Run Time	Remotely program your vehicle to run 5 to 25 minutes.
Ignition Controlled Door Locks	A programmable feature that locks and unlocks the doors when the brake is pressed or the ignition is cycled.
Run Time Confirmation	Remotely check the programmed run time of 5, 10, 15, 20 or 25 minutes.
Tach/Tachless Option	A programmable feature that lets you choose from the easy to install tachless operation or the wire-in, tach operation.
Parking Light Confirmation	Confirms that your vehicle has received a remote signal and will remain on if the engine is remotely started.
Dome Light Supervision	Never walk up to a dark vehicle again. When unlocking the doors by remote control, the dome light will come on and stay on for 1 minute. This feature will shut off when you activate the ignition switch or step on the brake.
Automatic Hot and Cold Start	Remotely program your car to start at a preset temperature. Automatically starts your car in extreme temperatures.
Automatic Start	Remotely program your car to start every 3 hours regardless of temperature.
Pit Stop Mode	Allows you to exit the vehicle while the engine remains running without leaving the key in the ignition switch.
Extended Range	Allows you to operate your system from up to 800 feet away.
Code Learning	Allows your remote starter/alarm to learn new remotes, should you want to add remotes, or if remotes are lost.
Limited Lifetime Warranty	Guarantees life-long protection.

SYSTEM COMPONENTS

Your system includes:

- 2- Four Button Remote Transmitters
- 1- Main Control Module
- 1- 16-Pin Wire Harness
- 1- 5-Pin Door Lock Harness
- 6- Heavy Gauge Wires w/ Spade Connectors
- 1- Hood Pin Switch
- 1- Extended Range Antenna

- 2- Window Antenna Clips
- 1- Warranty
- 1- Warning Sticker for Under the Hood
- 2- Bulldog Window Decals
- 1- Installation & Operation Guide
- 1- Bonus Installation Kit (with selected models including)
 - Installation Video
 - Computer-friendly Test Light
 - Electrical Tape
 - Wire Ties
 - Razor Knife

REQUIRED TOOLS

Unless your remote starter/alarm includes a Bonus Installation Kit you will need the following items: a sharp knife, electrical tape and a computer-friendly test light or volt meter. A 5/16 inch drill bit may be needed to install the hood pin switch. If the bottom of your dash on the driver's side will come off, you must remove it. If this is the case a screwdriver or a wrench may be needed.

TECHNICAL ASSISTANCE

Should you need help. First check our website at www.bulldogsecurity.com or call our toll-free Tech Support Hotline Monday through Friday 9AM-8PM and Saturday 10AM-4PM EST at 800-878-8007.

You must give the following information:

- Name
- Telephone Number with Area Code (Fax number if applicable)
- Year, Make, and Model of the vehicle
- The model you are installing
- The type of assistance you are requesting

If you give the above information you will be called back as soon as possible.
Please do not skip any steps.

BEFORE YOU BEGIN

If your vehicle has an anti-theft system, you will need an additional module, Part #781 or #791. Congratulations, you have purchased one of the most advanced remote starter/alarms systems ever made. Your new remote starter/alarm is a technological breakthrough utilizing the most advanced, state of the art technology and components. It is computer controlled and manufactured in the U.S.A. The dependability and variety of features make Bulldog Security the leader in the industry. Enjoy your new remote starter for years to come!

This remote system is designed to start your vehicle by sending a command signal from the remote transmitter. It is important that your installation be done in a well-ventilated area. **It is the responsibility of the owner to ensure that the remote system is not used to start the vehicle in an undesired location.**

It is recommended that a carbon monoxide detector be installed in the living area near a location where the vehicle may be garaged.

Since there are many different makes and models of vehicles, look at our website, www.bulldogsecurity.com

Read this manual thoroughly before starting the installation.

TACH/TACHLESS OPERATION

In most cases the decision to go with tachless mode will save time during the installation. If your vehicle is hard-starting then you should use tach mode.

MAKE SURE YOU PLACE THE WARNING STICKER UNDER YOUR HOOD.

PRECAUTIONS

This system is designed for use with vehicles equipped with fuel-injected, gasoline engines with automatic transmissions only.

SAFETY FIRST!

Never remotely start your vehicle indoors, with the keys in the ignition or unless the transmission is in park. A periodic safety check is recommended to ensure that your system is in proper working order.

DO NOT use mechanical wiring connections, such as crimp or snap together wire connectors. Instead, follow the instructions on page 3-4.

DO NOT disconnect the battery if the vehicle has an anti-theft-coded radio or is equipped with an airbag. Doing so may cause a warning light to be displayed which may require a trip to the dealer to be corrected.

DO NOT leave the interior or exterior lights on for an extended period of time as it may cause battery drain. Remove the dome light fuse from the vehicle's fuse box. **NOTE:** Starter systems do not work well with a partially discharged battery.

WARNING!

GENERAL MOTORS REAR WHEEL DRIVE VEHICLES AND DODGE DAKOTAS

All General Motors rear wheel drive vehicles and Dodge Dakotas built prior to 1996 do not have an electrical neutral safety switch. They have a mechanical neutral safety switch. The mechanical neutral safety switch operates as follows.

- a)The key will only turn to the start position when the gear selector is in park or neutral.
- b)The key can only be removed from the ignition switch when the gear selector is in the park position.

You must use special precautions with this system.

USING YOUR TEST PROBE

To operate your test probe, connect the black clip to a good chassis ground. Connect the red clip to a good 12V positive source. If the test probe is connected correctly, both the green and the red lights will be dimly illuminated. If a positive source is probed, the red light will glow bright and the green light will go out. If a negative source is probed, the green light will glow bright and the red light will go out.

MAKING WIRING CONNECTIONS

NOTE: In most cases you should not cut your vehicle wire in two.

1. Strip back two inches of insulation on the wire from the remote starter.



2. Strip back one inch of insulation on the wire you need to connect to.

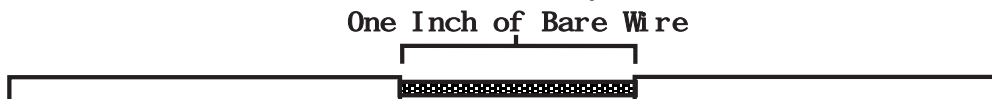

3. Separate the vehicle wire as shown. Make the separation large enough to fit the other wire through.



4. Insert the wire(s) from the starter through the hole as shown. If two or more wires are inserted, wrap them in opposite directions.

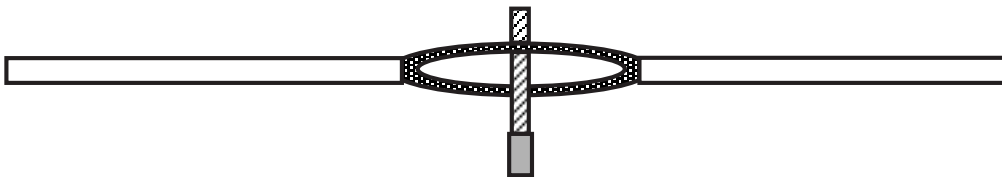

5. Wrap the wire around one side then the other and finally around itself as shown.

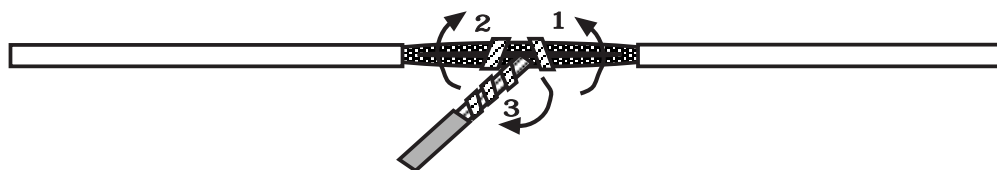

6. Use electrical tape to wrap. Be sure to cover the wire about two inches on either side of the connection. First pull the wire that you have just connected along side the wire you connected to, tape and wire tie them together. Use this method for all connections.



CAUTION: All wires must be wrapped with tape and wire tied.

MAKING END TO END CONNECTIONS

Use this method **ONLY** when connecting two separate wires end to end.

1. When tying two separate wires together at their ends, strip back one inch of insulation on both wires and separate the strands of wire as shown below.

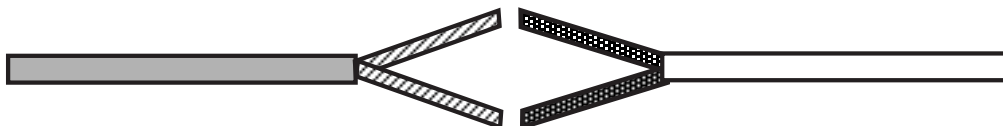

- Twist upper wires together, twist lower wires together as shown.

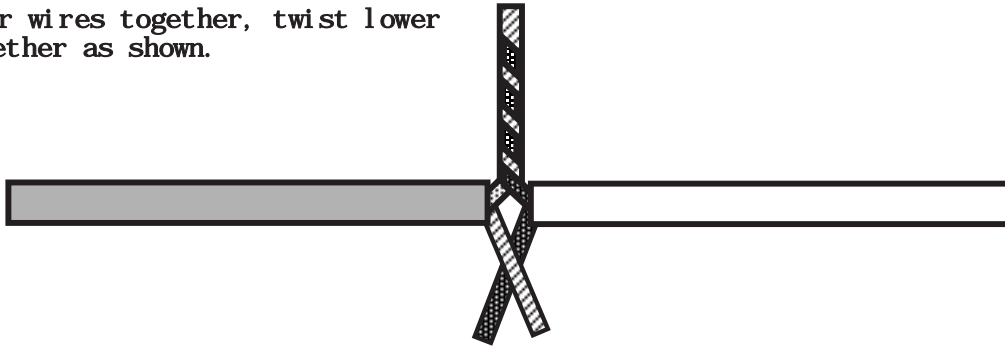

- Lay upper twisted pair of wires over right wire as shown. Bring lower twisted pair of wires up to meet the left wire as shown.

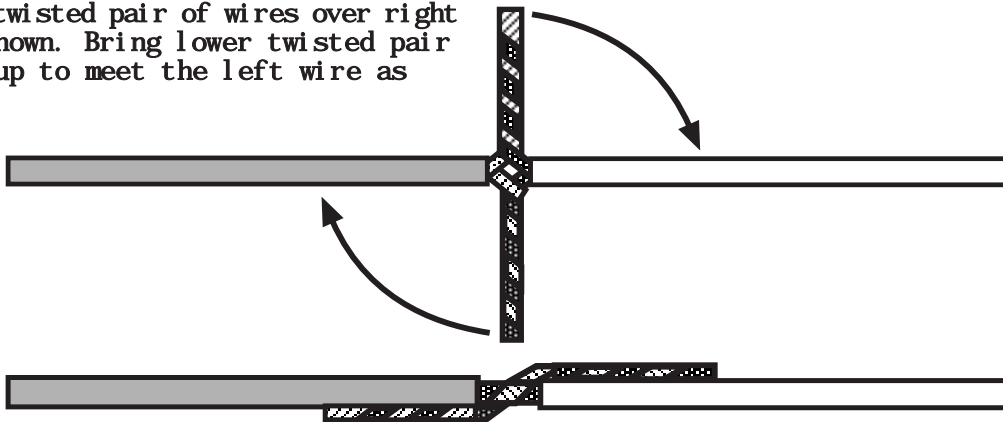

- Use electrical tape to wrap, be sure to cover about 2 inches on either side of connection. Secure with wire ties as shown.

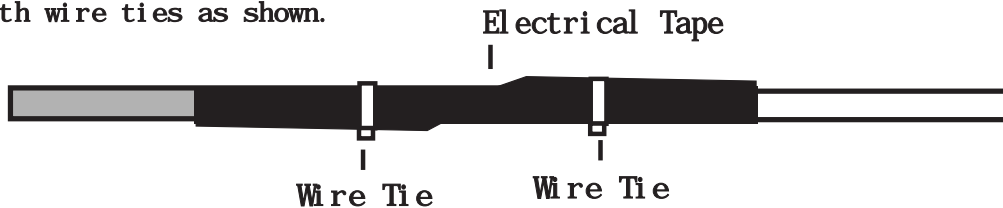

Use this method **ONLY** when connecting two separate wires end to end.

LOCATING & MAKING CONNECTIONS

Please see the wiring chart on this website.

Most of the wires you will be using will be in a taped or nylon sleeve coming from the ignition switch. You must find and remove about six inches of this outer covering for testing and connecting.

CONSTANT POWER (+12V, key in any position including off)

Make all connections as close to the ignition switch as possible.

These wire(s) are in your vehicle's main ignition harness, usually located in the steering column coming from the ignition switch. Probe each wire with your provided test probe. The correct wire(s) will show +12V and the RED light will glow bright on the test probe when the ignition switch is in these **5 positions (ACC-LOCK-OFF-RUN-CRANK)**.

- If your vehicle has only (1) constant power wire, attach both heavy gauge **RED** wires to it.
- If your vehicle has (2) constant power wires, attach one **RED** wire to each.

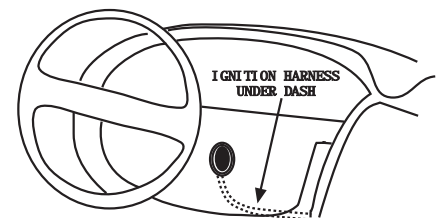

IGNITION WIRE(S) (+12V in run and crank position only)

Make all connections as close to the ignition switch as possible.

The ignition wire(s) are also located in the main harness coming from the ignition switch. Check your chart for probable colors and probe each wire with your provided test probe. The correct wire(s) will show +12V and the RED light will glow bright **only** when the ignition switch is in the **RUN AND CRANK** positions. The correct wires will not show +12V when in the OFF or ACCESSORY position. Most Ford, GM, and Chrysler vehicles have at least two (2) ignition wires. Most foreign vehicles have only one (1). **4**

1. If your vehicle has only one (1) ignition wire, as most 1993 and older domestic and import vehicles do, connect the heavy gauge **WHITE** wire to it.
2. If your vehicle has two (2) ignition wires, as most 1994 and newer vehicles do, connect the heavy gauge **RED with WHITE STRIPE** wire to the Ignition 2 wire.
3. If your vehicle has three (3) ignition wires, as some newer GMs, Fords and Chryslers do, connect the heavy gauge **WHITE** wire to the third ignition along with the Ignition 1 wire.

ACCESSORY WIRE(S) THAT POWER THE HEATER/BLOWER MOTOR

(+12V in run or on positions) This wire is also in the main ignition switch harness. Make this connection as close to the ignition switch as possible.

Most vehicles will have one (1) accessory wire; however **some** Fords, newer GM vehicles and Chrysler 94 and up will have two (2) or more accessory wires. Check your wire color chart and then verify these wire(s). The correct wire(s) will show +12V and the RED light will glow bright when the ignition switch is in the **RUN** or **ON** positions. This wire(s) will not show +12V when the ignition switch is in any other position.

1. If your vehicle has only one (1) accessory wire connect the heavy gauge **WHITE WITH BLACK STRIPE** wire to this wire.
2. If your vehicle has two (2) accessory wires, connect the **WHITE WITH BLACK STRIPE** wire to both accessory wires.
3. If your vehicle has three (3) accessory wires, connect the **WHITE WITH BLACK STRIPE** wire to all three.

STARTER/CRANK WIRE (+12V in the start position only)

Make all connections as close to the ignition switch as possible.

The starter/crank wire is also in the main harness. Check your chart for probable colors and verify the wire. The correct wire(s) will show +12V and the RED light will glow bright **only** in the **crank** position. This wire will not show +12V in any other position. Attach the **YELLOW WITH BLACK STRIPE** wire to it.

NOTE: Most Nissans will have two (2) starter/crank wires. Both must be connected to the **YELLOW WITH BLACK STRIPE** wire.

CHASSIS GROUND

Locate an easy to get to bolt or screw located under the driver's side of the dash and attach the **BLACK** ground wire from the 16-pin harness securely as pictured. A good ground is vital for your system to operate correctly.

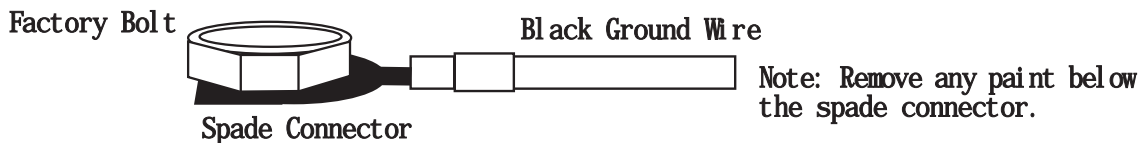

FACTORY ALARM SHUT DOWN WIRE (FASD) (-)

If your vehicle is equipped with a factory alarm system (as most new model vehicles with a factory keyless entry are) and you can disarm your factory alarm by using your key in the door. Check the owner's manual or contact your dealer to see if your vehicle is so equipped. Probe for a small gauge wire (usually found in the driver's side kick panel) that shows (-) ground and the GREEN light will glow bright when the door lock cylinder is turned to the unlock position using the key and will show +12V and the RED light will glow bright before turning the key. **NOTE:** Some factory disarm wires remain neutral (both the GREEN and the RED lights will be dimly illuminated) before you turn the key to unlock instead of +12v positive. Connect the **RED WITH BLACK STRIPE** wire from the 16-pin harness to this wire. See chart, page 21 for listing by manufacturer.

IGNITION OUTPUT (-) (Security bypass output wire)

This wire will be used to operate the security bypass module, VATS-WR, #781 or the #791 module. This **WHITE** wire holds a ground output the entire time the remote starter is activated. Connect this wire to the **WHITE** wire on the bypass module to control when the bypass is on and off.

HOOD PIN SWITCH (-)

This feature will keep the engine from starting, or shut off the engine when the hood is opened. Locate a good chassis ground, if at all possible do not install the pin switch in the rain gutter. Drill a 5/16 hole, insert the pin switch into the hole and tighten. Check for the hood adjustment, there is approximately 1/4" adjustment in the pin switch. Close the hood easy, making sure that the pin switch is not keeping the hood from closing all the way, if it does, cut off approximately 1/8" of the black plastic off of the top of the hoodpin switch and try closing the hood again. Check to make sure that the hoodpin switch remains neutral when the hood is closed and shows ground when the hood is open. Route the **BLACK WITH BLUE STRIPE** wire from the 16-pin harness through the firewall and connect it to the bottom of the hood pin switch.

BRAKE INPUT (+)

The brake wire is located on the switch near and above the brake pedal. The correct wire will show +12V and the RED light will glow bright only when the brake is pressed. Connect the **BLUE WITH BLACK STRIPE** from the 16-pin harness to this wire.

TACH INPUT (Optional)

If you have chosen the TACHLESS start option, simply proceed to the next step and skip the following instructions. Make sure to tape the **BLACK WITH WHITE STRIPE** wire if not used. For TACH mode connect the **BLACK WITH WHITE STRIPE** wire from the 16-pin harness to the negative side of the coil or the tach wire at the coil pack under the hood. To find the coil pack follow the spark plug wires back to their beginning point. To operate in tach mode, make sure to program tach option, see programming tach option page 10.

PARKING LIGHTS (+12V only with parking lights on)

Turn the parking lights to the ON position. (NOT YOUR HEADLAMPS). Probe the wire(s) coming from your headlamp control switch. The correct wire will show +12V and the RED light will glow bright only when the parking lights are ON. Connect the BROWN wire from the 16-pin harness to this wire. If this wire tests as a (-) negative, the GREEN light glows bright. See negative parking light diagram.

NEGATIVE PARKING LIGHT DIAGRAM ONLY Optional part #775 required.

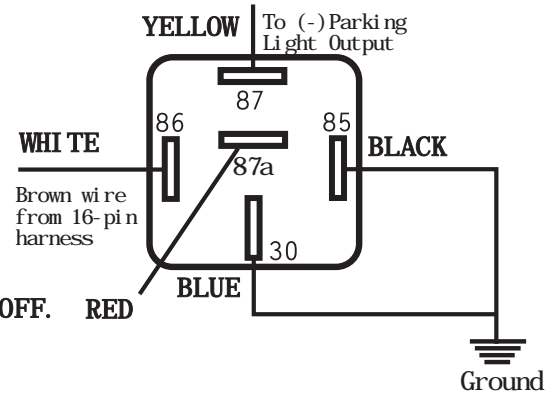

DO NOT USE THE RED WIRE, TAPE OFF. RED

HORN HONK OUTPUT (-)

The existing horn wire will usually be found in the main ignition switch harness in the steering column. Probe for a wire which will remain neutral (in some cases may show a (+) positive). When the horn is pressed this wire will test as a ground or (-) negative. Connect the GRAY WITH BLACK STRIPE wire from the 16-pin harness to the horn honk wire in the vehicle.

SIREN OUTPUT (+) (Optional Siren Part #724)

Connect the GRAY wire from the 16-pin harness to the RED (+) positive input on the siren. Make sure you ground the BLACK wire on the siren.

DOOR PIN TRIGGER

To determine if your door pin is turned on with (+) positive or (-) negative trigger, probe for a wire in the driver's side kick panel that switches polarity when the door is closed then opened. You can also find this wire going to the under dash courtesy lights.

- If this wire reads +12V when the door is open and (-) ground when the door is closed, it is (+) positive. (most Fords)
- If this wire reads (-) ground when the door is open and +12V when the door is closed, it is (-) negative.

If your vehicle is a (+) positive door pin connect the BLACK WITH WITH YELLOW STRIPE wire from the 16-pin harness to the door pin wire. Follow the instructions, Programming Door Pin Inputs, page 10 to program your unit to work with a (+) positive door pin. If your vehicle is a (-) negative door pin, connect the BLACK WITH WITH YELLOW STRIPE wire from the 16-pin harness to the door pin wire. The unit will not need to be programmed. NOTE: When testing the door pin wire, make sure the dome light is on. Some vehicles, if the door is left open for a period of time, the dome light will go out, resulting in a false reading.

SHOCK SENSOR INPUT (-) (Optional)

The GREEN WIRE on the 16-pin harness is a negative input to be used when installing an external shock sensor, motion sensor or trunk pin. If this wire is not used, make sure to tape it up.

INSTALLING STARTER IMMOBILIZER (-) Output (Optional part #773)

Locate the same starter/crank wire located in the main wiring harness that you have tied the YELLOW WITH BLACK STRIPE wire from the control module. Cut the starter/crank wire in half, making sure that the YELLOW WITH BLACK STRIPE wire from the control module stays on the "starter side" and not the "switch side" of your starter immobilizer circuit. Connect the RED wire from the starter immobilizer to the "switch side" of the starter/crank wire then connect the WHITE wire to the "starter side" of the starter/crank wire. Connect the ORANGE wire from the starter immobilizer to the ORANGE wire on the 16-pin harness. NOTE: You will need to cut factory wiring to make an end to end connection, see "Making Connections" on page 3-4.

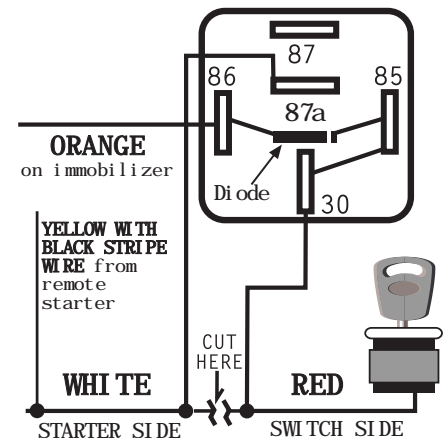

NEUTRAL SAFETY SWITCH

MECHANICAL NEUTRAL SAFETY SWITCH (Rear Wheel Drive Only)

When installing a Bulldog remote starter on GM vehicles or Dodge Dakotas built prior to 1996, you must:

Use the diagram below to create a circuit that will prevent the remote starter from starting the vehicle unless the key is removed from the ignition switch.

light will glow bright on both the lock and the unlock wires. Press and hold the lock button on the switch and test the lock wire. The correct wire will test (+) positive and the RED light will glow bright. Release the lock button and this wire should show a (-) negative and the GREEN light will glow bright. Now press and hold the unlock button on the switch and test the unlock wire. The correct wire will test (+) positive and the RED light will glow bright. Release the unlock button and this wire should show a (-) negative and the GREEN light will glow bright. Your vehicle has a "Type A" door locking system. Make sure to mark which wire is lock and unlock. Connecting Door Locks. **NOTE:** "Type A" and "Type C" locks will test the same. Make sure you run both tests before making your connections.

"Type B" Door Lock Test (Most Imports, some newer Fords)

Probe both of your door lock wires going to the door lock switch usually located in the driver's kick panel. Probe the lock and the unlock wires, the test probe will glow both GREEN and RED (dimly) on both the lock and the unlock wires. Press and hold the lock button on the switch and test the lock wire. The correct wire will test (-) negative and the GREEN light will glow bright. Release the lock button and this wire should again glow both GREEN and RED (dimly). Now press and hold the unlock button on the switch and test the unlock wire. The correct wire will test (-) negative and the GREEN light will glow bright. Release the unlock button and this wire should again glow both GREEN and RED (dimly). Your vehicle has a "Type B" door locking system. Make sure to mark which wire is lock and unlock. Make sure to mark which wire is lock and unlock.

"Type C" Door Lock Test (Most Fords, some Chryslers, GM Trucks)

Once you have located the lock and unlock wires in the vehicle using the wire color chart in this manual or from our website, you will need to perform the same test as for the Type A system. Once you have completed this test, and it tests the same as a Type A (as it should) you will need to cut the lock wire in two. Now try the door lock switch in both the lock and unlock positions. The door locks should not function, this is a Type C system. Proceed to Connecting Door Locks. **NOTE:** If for any reason the doors unlock but do not lock with this wire, cut in two, this is a Type A system.

"Type A" (+) Positive (5-pin harness)

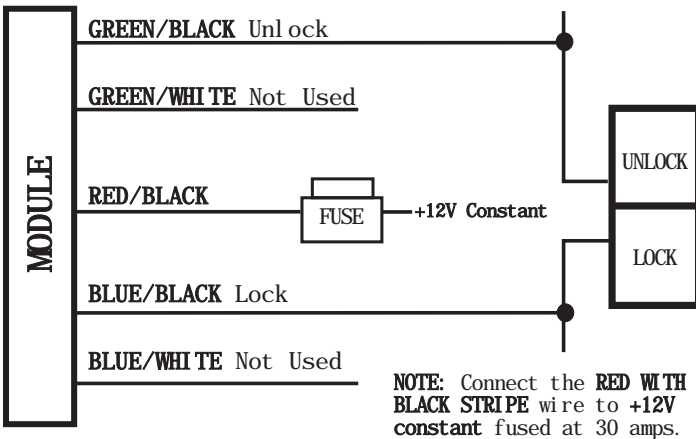

"Type B" (-) Negative (5-pin harness)

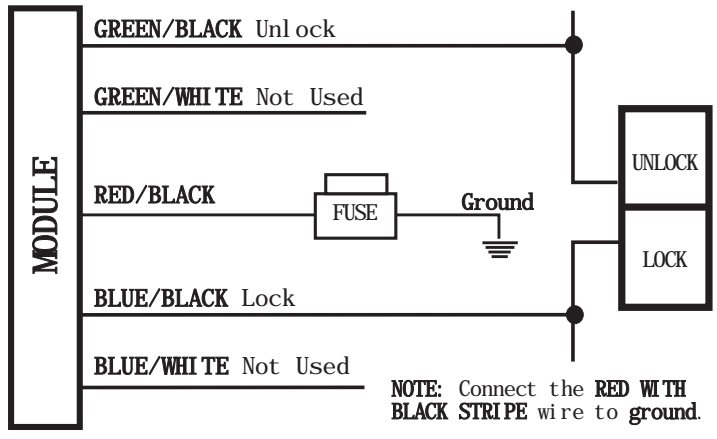

NOTE: Once you have made the connections for the 5-pin door lock harness, you will need to plug the door lock harness into the main module 5-pin plug on the front of the unit.

"Type C" Reverse Polarity (5-pin harness)

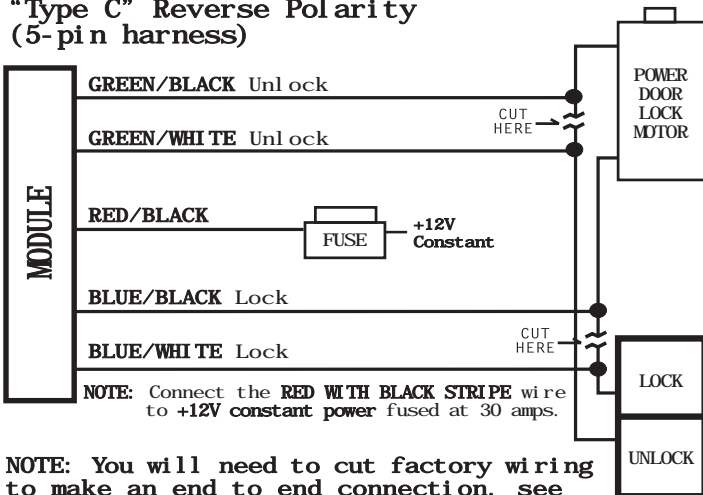

Once you have determined that your door locks are Type C system, you must cut the unlock wire in two. Now you need to determine which wire is coming from the switch and the motor sides of each lock and unlock wire. First, test the lock wires, press and hold the door lock switch in the lock position. Test both lock wires, the wire that shows (+) positive, and the RED light glows bright, will be the switch side and the other wire will be the motor side of this circuit. Mark these wires. Repeat these steps for the unlock wire by pressing and holding the door lock switch in the unlock position. The wire that shows (+) positive, and the RED light glows bright, will be the switch side and the other wire will be the motor side of the unlock circuit.

NOTE: You will need to cut factory wiring to make an end to end connection, see "Making Connections" on page 8.

DOME LIGHT

To determine if your dome light is turned on with (+) positive or (-) negative trigger, probe for a wire in the driver's side kick panel that switches polarity when the door is closed, then opened. You can also find this wire going to the under dash courtesy lights.

- If this wire tests (+) positive, the RED light glows bright when the door is open (as with most Fords) and when the door is closed, this wire tests as a (-) negative, the GREEN light glows bright, this is (+) positive dome light.
- If this wire tests (-) negative, the GREEN light glows bright, when the door is open and when the door is closed, this wire tests as a (+) positive, the RED light glows bright, this is a (-) negative dome light.

If your dome light is a (-) negative (as most others are), connect the VIOLET wire to the dome light wire from the 16-pin harness.

If your dome light is (+) positive (most Fords) you must add Part #775 to use this option. See diagram.

Optional part #775 required.

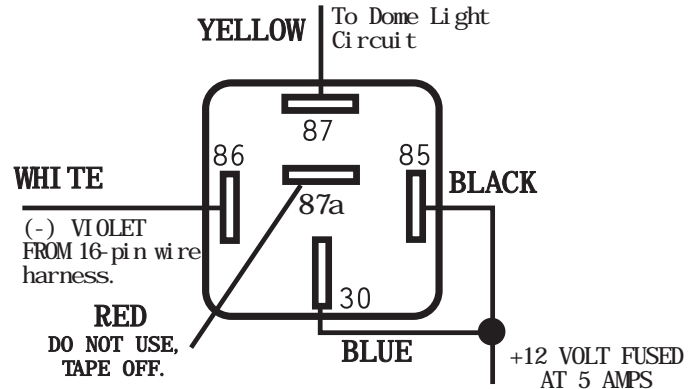

NOTE: When testing the door pin wire, make sure the dome light is on. Some vehicles, if the door is left open for a period of time, the dome light will go out, resulting in a false reading.

TRUNK RELEASE AND SLIDING VAN DOOR RELEASE (+)

Locate the trunk release or sliding van door release wire coming from the back of the release switch. To determine if your release is tripped by a (+) positive or a (-) negative (most trunk release or van door release switches are (+) positive). Press the "trunk" or "sliding door" button, if the RED light glows bright, you have a (+) positive release. If the GREEN light glows bright you have a (-) negative release.

If your release is a (-) negative an optional part #775 is required. Connect the WHITE WITH RED STRIPE wire to the WHITE wire of the optional relay. Attach the BLACK wire and the BLUE wire to chassis ground and attach the YELLOW wire to the release output wire on the vehicle. Please use figures above for correct connections. If your release wire is a (+) positive, connect the WHITE with RED stripe wire from the 16-pin harness to the release wire in the vehicle's harness.

AUXILIARY INPUT (-)

If you wish to use this starter with an aftermarket alarm, connect the BLUE wire from the 16-pin harness to the second or third channel (-) output of your existing alarm. When the output is activated, a (-) signal will be supplied to the remote starter which will start the vehicle.

NEGATIVE TRUNK/
SLIDING DOOR RELEASE ONLY
Optional part #775 required.
TO FACTORY TRUNK/SLIDING DOOR WIRE WIRE

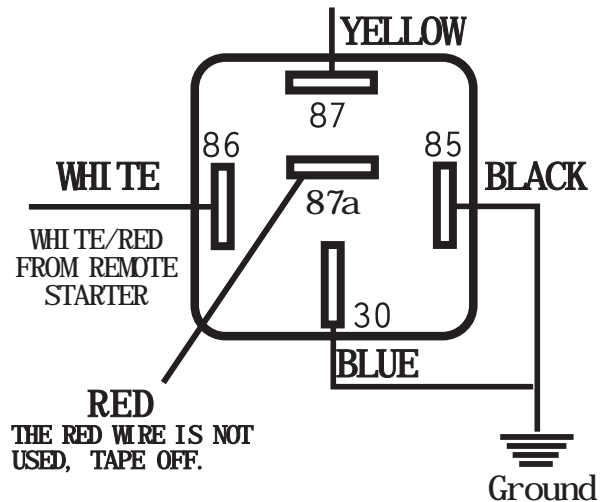

OPERATOR PROGRAMMING INSTRUCTIONS

Adding Additional Remotes

Press and hold brake. Next, press and hold **Button #1** on the working remote until the parking lights flash once, release. Press and release **Button #4** on the new remote. The parking lights will flash three (3) times confirming that the new remote was learned.

Cold Start On and Off (Degree Select)

Press and hold brake. Next, press and hold **Button #2** until the parking lights flash twice, release, press and hold **Button #2**. Each parking light flash is a progression in degrees. Flash #1 is -40°F, flash #2 is -30°F, flash #3 is -20°F, flash #4 is -10°F, flash #5 is 0°F, flash #6 is +10°F, flash #7 is +20°F. Two rapid flash parking light flashes is Cold Start Off. Release the brake, the parking lights will flash three (3) times. NOTE: Factory setting is OFF.

Hot Start (Degree Select)

Press and hold the brake, then press and hold **Button #2** (arm/disarm) until the parking lights flash twice. Release **Button #2**. Press and hold **Button #3**, the parking lights will flash once. Each continuous flash represents a progression in degrees: one (1) flash=160°F, two (2) flashes=150°F, three (3) flashes=140°F, four (4) flashes=130°F, five (5) flashes=120°F, six (6) flashes=110°F. To disable Hot Start, press and hold **Button #3** until the parking lights flash six (6) times, then two (2) quick flashes 7 and 8. The Hot Start is now disabled. Release the brake, the parking lights will flash three (3) times, the programming is now entered. NOTE: The factory setting is Hot Start off. NOTE: Only Cold and Hot Start functions can be enabled at the same time. If **Button #1** is pressed for programming, Cold/Hot Start is disabled. When **Buttons #2** and **#3** are pressed, then the Automatic and Low Voltage Starts are disabled.

Automatic Start - On

Press and hold brake. Press and hold **Button #2** until the parking lights flash twice. Release. Press and release **Button #1**. The parking lights will flash once. The automatic start is programmed ON. Release the brake, the parking lights will flash three (3) times. **NOTE:** Factory setting is OFF.

Automatic Start - Off

Press and hold brake. Press and hold **Button #2** until the parking lights flash twice. Release. Press and release **Button #1**. The parking lights will flash twice. The automatic start is programmed OFF. Release the brake, the parking lights will flash three (3) times. **NOTE:** Factory setting is OFF.

Tach Mode - ON

Press and hold the brake pedal. Press and hold **Button #3** until the parking lights flash three (3) times. Release. Press and release **Button #4**, the parking lights will flash twice. Release the brake, the parking lights will flash three (3) times. The unit is now programmed for Tach Mode. **NOTE:** Factory setting is Tachless Start ON.

Tachless Mode - ON

Press and hold the brake pedal. Press and hold **Button #3** until the parking lights flash three (3) times, release, press and release **Button #4**, the parking lights will flash once. Release the brake, the parking lights will flash three (3) times. The unit is now programmed for Tachless Mode.

Tach Learn

To program your unit to Learn your tach signal. Press and hold the brake pedal, now press and hold **Button #2** until the parking lights flash twice. Release **Button #2**. Turn your ignition key to the RUN or ON position while still holding the brake, press and hold **Button #4** until the vehicle starts. After the engine starts, release **Button #4** to disengage the starter. Release the brake and turn the ignition OFF. After the Tach Learn is complete, the unit will flash the parking lights once to show that the Tach Learn is now programmed. Now try the remote starter, to be sure there is no over crank and the unit does crank long enough.

Programming Lock with Brake, Unlock with Ignition Off

Press and hold the brake, then press and hold **Button #3** (trunk) until the parking lights flash three (3) times. Release **Button #3**. Press and release **Button #2**, the parking lights will flash once. The unit will now lock with the brake and unlock when the ignition is turned off. Press and release **Button #2** again, the parking lights will flash twice. The Lock with Brake feature is now turned off. Release the brake, the parking lights will flash three (3) times. The programming is now entered. **NOTE:** Factory setting is Lock with Brake off.

Door Lock Pulse Length (Long) (For European type door locks)

Press and hold brake. Next, press and hold **Button #3**, the parking lights will flash three (3) times, release, press and release **Button #1**. The parking lights will flash once, the door lock pulse length will be 3.5 seconds. Release the brake, the parking lights will flash three (3) times.

Door Lock Pulse Length (Short) (For domestic type door locks)

Press and hold brake. Next, press and hold **Button #3**, the parking lights will flash three (3) times, release, press and release **Button #1**. The parking lights will flash twice, the door lock pulse length will be 0.7 seconds. Release the brake, the parking lights will flash three (3) times. **NOTE:** Factory setting is SHORT pulse length.

Dual Pulse Door Lock

If your vehicle requires a Dual Pulse Lock output to lock the doors or to arm your factory alarm, you must program your unit to do this. Press and hold the brake pedal, press and hold **Button #3** until the parking lights flash three (3) times. Release **Button #3** then press **Button #3** again and release. The parking lights will flash once the unit is now programmed to dual pulse the lock output. Release the brake and the parking lights will flash three (3) times. To turn Dual Pulse Lock off, repeat the above steps, then when you press and release **Button #3**, the parking lights will flash twice. Release, the brake and the parking lights will flash three (3) times.

Dual Pulse Door Unlock

If your vehicle requires a Dual Pulse Unlock output to unlock the doors or to disarm your factory alarm, you must program your unit to do this. Press and hold the brake pedal, press and hold **Button #4** until the parking lights flash four (4) times. Release **Button #4** then press **Button #3** and release. The parking lights will flash once the unit is now programmed to dual pulse the unlock output. Release the brake and the parking lights will flash three (3) times. To turn Dual Pulse Unlock off, repeat the above steps, then when you press and release **Button #3**, the parking lights will flash twice. Release the brake, the parking lights will flash three (3) times.

Programming Doorpin Inputs

Press and hold the brake, then press and hold **Button #4**, the parking lights will flash (4) times, release. Now press and release **Button #1**. The parking lights will flash once, the unit is now programmed for a (+) positive doorpin. Press and release **Button #1** again, the parking lights will flash twice, the unit is now programmed for a (-) negative doorpin.

Programming Runtime

Press and hold **Button #4**. The parking lights will flash once for every five (5) minutes you want the engine to run. Release button at desired runtime. Maximum length, 25 minutes.

Clearing the Memory of the Unit

Press and hold the brake pedal, now cycle the key in the ignition switch from OFF to RUN (not start) five (5) times within four (4) seconds. Release the brake and try the remote. The unit should not function with the remote. If the unit does not function, unplug the unit from both harnesses, wait one (1) minute and plug it back in. Press **Button #4** (stop) the parking lights will flash three (3) times, the unit is now back to factory default and ready to operate. If memory does not clear, check to see if the heavy gauge **WHITE** wire is on the proper ignition wire.

HOW TO USE YOUR REMOTE TRANSMITTER

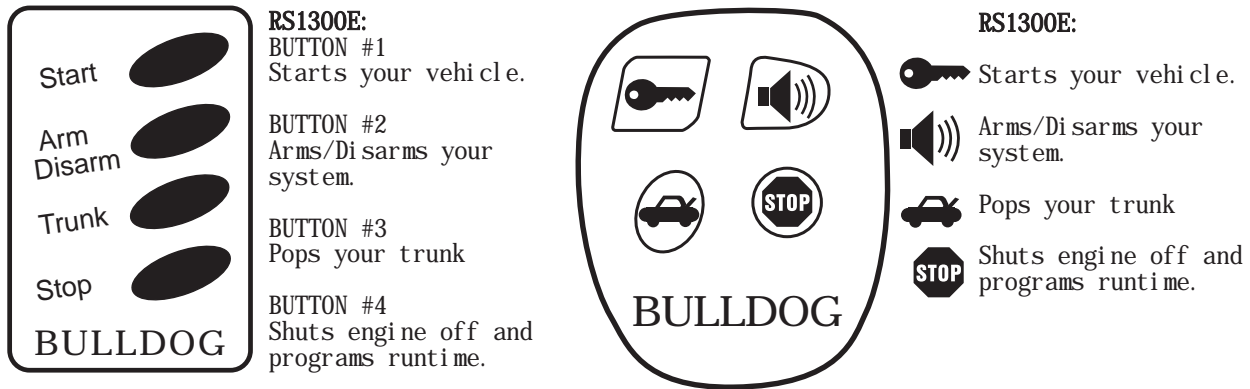

Starting the Vehicle with the Remote Transmitter

Press and release button #1 (start). The parking lights will flash once, confirming the car starter received the signal. The car will then start and the parking lights will turn on and remain on while the vehicle is running. To shut off the engine before the preset time, press Button #4, press the brake pedal or open the hood. **NOTE:** In tachless mode, parking lights will wait approximately 10 seconds before turning on after the vehicle is running.

Pit Stop: Exiting the Car with the Engine Running

Make sure the transmission is in park; press Button #1 before turning the ignition switch off. (The engine will remain running for the preset time.)

Keyless Entry Operation

Press Button #2, the system will arm, the doors will lock and the parking lights will flash once. Press Button #2 again, the system will disarm, the doors will unlock and the parking lights will flash twice. The parking lights will remain on for one minute or until you turn the ignition on and press the brake.

Dome Light Option

The remote starter includes an optional output that can be used to operate the dome light when pressing Button #2, unlock your power door locks. The dome light will remain on for one minute or until you turn the ignition on or press the brake.

Trunk Release Output

The remote car starter includes an optional output from our unit that with a press and release of Button #3 will give a pulse of (+) positive voltage for .75 seconds and if Button #3 is held down, this output will hold (+) positive voltage on this wire until Button #3 is released. The parking lights will remain on for as long as this button is held down. With a momentary press of this button the parking lights will flash once. This output can be used to operate a power trunk release (Part #775 may be required for some imports and some domestics), power sliding doors and rear lift gates (Part #775 may be required on some domestic and imported mini vans) operate a window roll up module (Part #706 required) or operate a power sunroof (Part #775 may be required).

Runtime Confirmation (Engine Not Running)

To check programmed runtime, press and release Button #4, the parking lights will flash for the programmed length of time. Each flash will equal 5 minutes of runtime. **Example: Three parking light flashes represents 15 minutes of runtime.**