

Connecting a T-Harness to the H1 Harness on the DELUXE 200 and DELUXE 500 Units

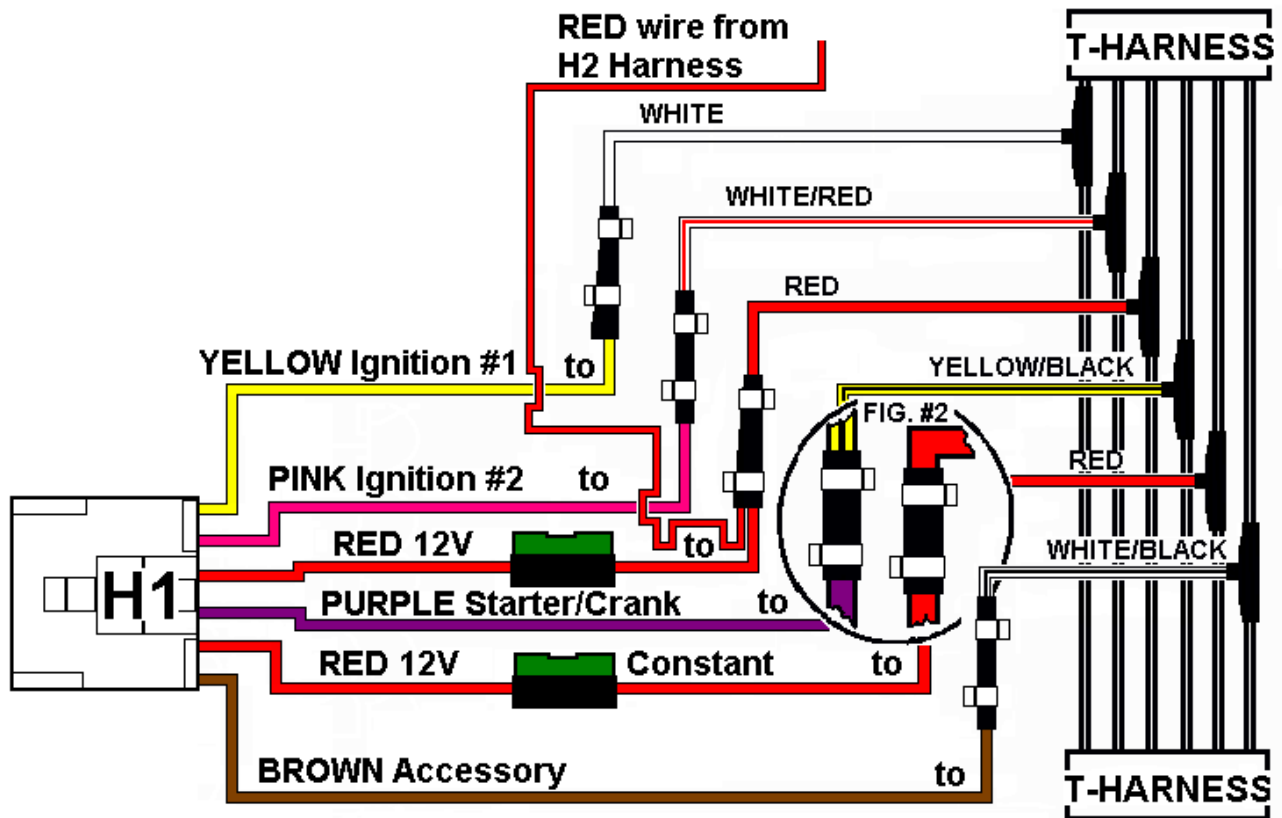
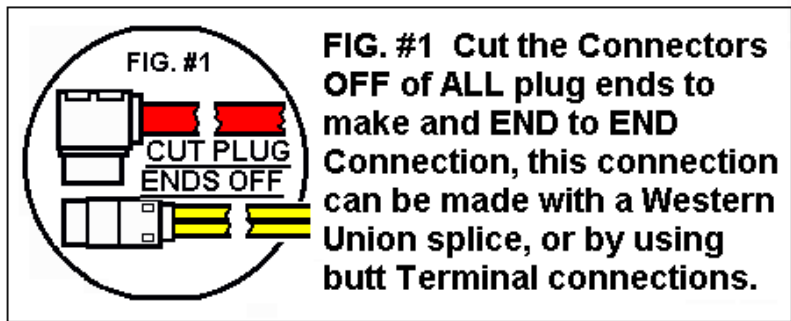

FIG. #2 Shows the connection between the T-Harness outgoing connectors and the H1 Harness from the unit. Note ** this is an END to END connection.

EXAMPLE: