

MODEL IF114
VATS/PASSLOCK/TRANSPONDER
UNIVERSAL ALARM BYPASS MODULE

This module lets you bypass virtually any type of **Vehicle Anti-Theft System** on the market today to remotely start your vehicle without permanently disabling the **Vehicle's Factory Anti-Theft System**.

In 1985, General Motors came out with their first Vehicle Anti-Theft System known as **VATS** that uses a Resistor Pellet in the key. Since this time, other manufactures have been following suit with their own Anti-Theft Systems. Most use a **Transponder Anti-Theft System** – a small Transmitting device in the head of the key that communicates a Security Code to the vehicle upon placing the Ignition key in the Ignition switch of the vehicle.

Contents:

- 1 VATS/Passlock/Transponder module
- 1 8-Pin Wire Harness
- 1 Transponder Loop w/connector
- 2 Cable Ties
- 1 Installation Booklet
- 2 Double-stick Foam Tape

FRONT VIEW

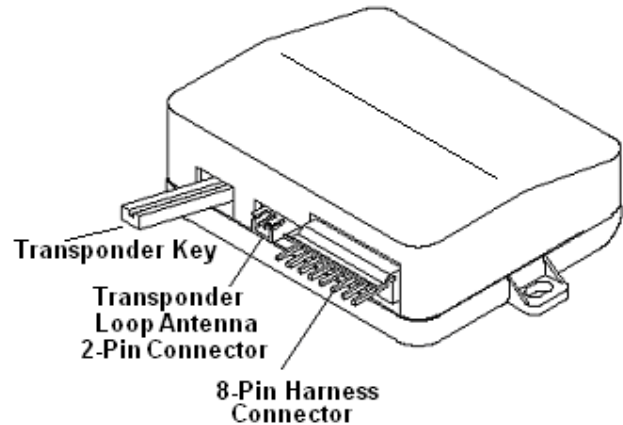

BACK VIEW

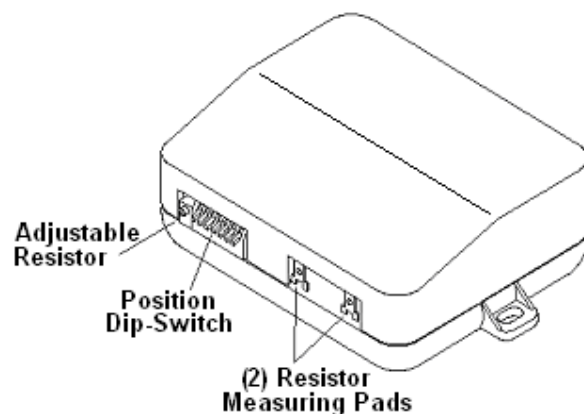

List of vehicles and the types of security systems:

Acura 3.2TL 98+	Transponder	GMC Suburban 98+	Passlock II
Acura RL 98+	Transponder	GMC Sonoma 98+	Passlock II
Audi A4, A6, A8 98+	Transponder	GMC Sierra 98+	Passlock II
BMW (all 97 +)	Transponder	GMC Safari 98+	Passlock II
Buick Century 97+	VATS	GMC S-15 98+	Passlock II
Buick LeSabre 90 – 96	VATS	GMC Envoy 98+	Passlock II
Buick Park Ave 91 – 96	VATS	GMC Denalli 98+	Passlock II
Buick Park Ave 97+	VATS	GMC Yukon 98+	Passlock II

Buick Regal 93 – 96	VATS	Honda Accord 98+	Transponder
Buick Riviera 93 – 96	VATS	Honda Odyssey 98+	Transponder
Buick Riviera 93 – 96	VATS	Honda Odyssey 98+	Transponder
Buick Roadmaster 93 – 96	VATS	Honda Prelude 98+	Transponder
Cadillac Allante	VATS	Honda Prelude 98+	Transponder
Cadillac Brougham	VATS	Isuzu Hombre 98+	Passlock II
Cadillac Catera 97 +	VATS	Jeep Grand Cherokee 99+	Transponder
Cadillac DeVille 92 - 96	VATS	Jeep TJ (Wrangler) 99+	Transponder
Cadillac DeVille 99	Transponder	Lexus (all 97+)	Transponder
Cadillac Escalade 99+	Passlock II	Lincoln Continental 97+	Transponder
Cadillac Eldorado 89 - 98	VATS	Lincoln Mark VIII 97+	Transponder
Cadillac Eldorado 99+	Transponder	Lincoln Navigator 97+	Transponder
Cadillac Fleetwood 90- 96	VATS	Lincoln Towncar 97+	Transponder
Cadillac Seville 90 - 98	VATS	Mercedes (all 97+)	Transponder
Cadillac Seville 99+	Transponder	Mercury Cougar 99	Transponder
Chevrolet Venture 99+	Transponder	Mercury Mystique 97+	Transponder
Chevy Astro Van 98+	Passlock II	Mercury sable 96+	Transponder
Chevy Blazer 98+	Passlock II	Nissan Maxima 98+	Transponder
Chevy Camaro 86+	VATS	Oldsmobile Intrigue 98+	Passlock II
Chevy Cavalier 96-00	Passlock I	Olds. Cutlass 97+	Passlock II
Chevy Cavalier 2001+	Passlock II		
Chevy Monte Carlo 2000+	Passlock II	Oldsmobile Achieva 95-98	Passlock I
Chevy Express 1998	Passlock II	Oldsmobile Alero 99+	Passlock II
Chevy Lumina 96+	VATS	Oldsmobile Aurora	VATS
Chevy Malibu 97+	Passlock II	Oldsmobile Bravada 98+	Passlock II
Chevy Monte Carlo 96 - 99	VATS	Oldsmobile Eighty-Eight	VATS
Chevy Pickup Full-size 98+	Passlock II	Oldsmobile Ninety-Eight	VATS
Chevy S-10 98+	Passlock II	Oldsmobile Silhouette 99+	Transponder
Chevy Suburban 98+	Passlock II	Pontiac Bonneville 89+	VATS
Chevy Tahoe 98+	Passlock II	Pontiac Firebird 88+	VATS
Chevy Van 98+	Passlock II	Pontiac Grand Am 96 -98	Passlock I
Chevy Venture 1998 +	Transponder	Pontiac Grand Am 99+	Passlock II
Chrysler Concorde 98+	Transponder	Pontiac Grand Prix 92 - 96	VATS
Chrysler Sabring Conv 98+	Transponder	Pontiac Montana 99+	Transponder
Chrysler LHS 99	Transponder	Pontiac Sunfire 96 - 99	Passlock I
Chrysler 300 M 99+	Transponder	Pontiac Sunfire 2000+	Passlock II
Dodge Intrepid 98+	Transponder	Porsche (all 97+)	Transponder
Dodge Neon 2000+	Transponder	Saab (all 97+)	Transponder
Ford Contour 97+	Transponder	Saturn 2001+	Passlock II
Ford Crown Vic 96+	Transponder	Toyota Avalon 98+	Transponder
Ford F-Series 2000+	Transponder	Toyota Camry 98+	Transponder
Ford Windstar 2000+	Transponder	Toyota Land Cruiser 98+	Transponder

Toyota Solara 99+	Transponder
Toyota Supra 98+	Transponder
Volkswagon Passat 98+	Transponder
Volvo (all 98+)	Transponder

First determine what type of **Anti-Theft System** you have in your vehicle. If unsure – follow the chart on the previous page to determine the system you have. There are several types of systems as outlined below:

General Motors VATS, PASSLOCK I and PASSLOCK II Anti-Theft Systems: For these, you will be required to **dial-in a resistor value** that matches the **Resistance** on your **vehicles Anti-Theft System**. The method is described on the following pages for each type of system using the **Dip Switches** and the **Variable/Adjustable Resistor**. The **Variable Resistor** is a **(10)Ten turn Potentiometer** which can be dialed up from **(0) Zero Ohms to 1,000 Ohms**.

SATURN vehicles (1996-2000) simply hook up as shown on **Page 9**.

SATURNS 2001 and UP use **Passlock II Systems**.

TRANSPONDER Anti-Theft Systems require an **Extra Programmed Ignition Key** to be placed inside the **Bypass Module**. Follow the directions on **Pages 10 and 11**.

Use this chart with VATS, PASSLOCK I and PASSLOCK II.

Dip Switch #	<u>2</u>	<u>3</u>	<u>4</u>	<u>5</u>	<u>6</u>	
Resistor Value	0.825	1.65	3.32	6.65	13.3	<u>Final Resistance (k ohms)</u>
	ON	ON	ON	ON	ON	0.000 +Trimpot Value
	OFF	ON	ON	ON	ON	0.825 +Trimpot Value
	ON	OFF	ON	ON	ON	1.650 +Trimpot Value
	OFF	OFF	ON	ON	ON	2.475 +Trimpot Value
	ON	ON	OFF	ON	ON	3.320 +Trimpot Value
	OFF	ON	OFF	ON	ON	4.145 +Trimpot Value
	ON	OFF	ON	ON	ON	4.970 +Trimpot Value
	OFF	OFF	OFF	ON	ON	5.795 +Trimpot Value
	ON	ON	ON	OFF	ON	6.650 +Trimpot Value
	OFF	ON	ON	OFF	ON	7.475 +Trimpot Value
	ON	OFF	ON	OFF	ON	8.300 +Trimpot Value
	OFF	OFF	ON	OFF	ON	9.125 +Trimpot Value
	ON	ON	OFF	OFF	ON	9.970 +Trimpot Value
	OFF	ON	OFF	OFF	ON	10.795 +Trimpot Value
	ON	OFF	OFF	OFF	ON	11.620 +Trimpot Value

OFF	OFF	OFF	OFF	ON	12.445 +Trimpot Value
ON	ON	ON	ON	OFF	13.300 +Trimpot Value
OFF	ON	ON	ON	OFF	14.125 +Trimpot Value
ON	OFF	ON	ON	OFF	14.950 +Trimpot Value
OFF	OFF	ON	ON	OFF	15.775 +Trimpot Value
ON	ON	OFF	ON	OFF	16.620 +Trimpot Value
OFF	ON	OFF	ON	OFF	17.445 +Trimpot Value
ON	OFF	OFF	ON	OFF	18.270 +Trimpot Value
OFF	OFF	OFF	ON	OFF	19.095 +Trimpot Value
ON	ON	ON	OFF	OFF	19.950 +Trimpot Value
OFF	ON	ON	OFF	OFF	20.775 +Trimpot Value
ON	OFF	ON	OFF	OFF	21.600 +Trimpot Value
OFF	OFF	ON	OFF	OFF	22.425 +Trimpot Value
ON	ON	OFF	OFF	OFF	23.270 +Trimpot Value
OFF	ON	OFF	OFF	OFF	24.095 +Trimpot Value
ON	OFF	OFF	OFF	OFF	24.920 +Trimpot Value
OFF	OFF	OFF	OFF	OFF	25.745 +Trimpot Value

All resistor values shown are in 'K-Ohms' or 1,000 Ohms. Thus the 1.650 value shown in the (3) Third row is **1,650 Ohms** or **1.65K Ohms**.

	<u>Dip Switch #1</u>	<u>Dip Switch #7</u>
VATS	OFF	OFF
PASSLOCK I	ON	ON
PASSLOCK II	OFF	OFF

VATS:

1. Measure the resistance of the little Pellet on the Ignition Key. It should be between **392 Ohms** and **11,800 Ohms**. To do this, put the Ohm Meter probes on each side of the Key Pellet. The Resistance value should be close to one of the following (all values in Ohms): **392, 523, 681, 887, 1.13K, 1.87K, 3.01K, 3.74K, 4.75K, 6.04K, 7.50K, 9.53K, 11.8K**.
2. Locate the closest value that is less than your desired value. Set **Dip Switches 2 through 6** to match the chart on **Page 4**.
3. Put your **Ohm Meter (multi-meter)** probes on the **(2)Two Silver Resistance Measuring Pads** through the opening shown in the drawing – making good contact with these **(2)Two Silver Resistance Measuring Pads** on the board. **(See drawing on page 1)**. Or put your **(2)Two Ohm Meter (multi-meter)** probes into the **(2)Two holes** on the bottom of the case making contact with the underside of the **Silver Pads**. Either contact point method will work.
4. With the probes held firmly – dial-in the final resistance value needed for your system by turning the screw on the variable resistor on the side of the unit next to the Dip Switches. Turn the screw unit the resistance value matches the resistance value of the Pellet on the Key.
5. Locate the pair of **VATS wires** (sometimes **(2) WHITE** or **(1) WHITE/BLACK striped** and **(1) PURPLE/BLACK striped**) **20 Gauge wires**, these wires are often in a **ORANGE** or **BLACK Plastic Tube**. Be careful not to cut into the **YELLOW Air Bag wires!** The **Air Bag wires** are often in a **YELLOW Plastic Tube** that is clearly marked. The **VATS wires** run from the **Ignition Switch down the Steering Column to the under side of the dash**. Connect the Universal Bypass

Module using the diagram below.

6. When connecting the Anti-Theft Bypass Module to your Remote Starter, you will need to activate this Bypass Module by connecting it in different ways depending on the Remote Starter you have. Attach the **WHITE/GREEN (-)Security Bypass Output** wire from the 8-Pin Harness to: if the unit you are using has a **4-Relay Pack**, tap this **WHITE/GREEN** wire into the Thin **WHITE** wire in the middle of the **3-Pin Plug**, if the Remote Start does not have a 4-Relay Pack and the Relays are On-Board, connect the **WHITE/GREEN** wire to the **WHITE, YELLOW or YELLOW BLACK (-)Negative Ignition Output or (-) Security Bypass Output** wire from the Main Harness on these Remote Starters. On the **DELUXE 200, DELUXE 200B or DELUXE 500 Models**, connect this **GREEN/WHITE** wire to the **BLUE/BLACK Ignition 3 Control Output** wire, the **H4/9** wire or **H7/1** wire.

VATS/PASSKEY Diagram for 8-Pin Harness on Bypass Module:

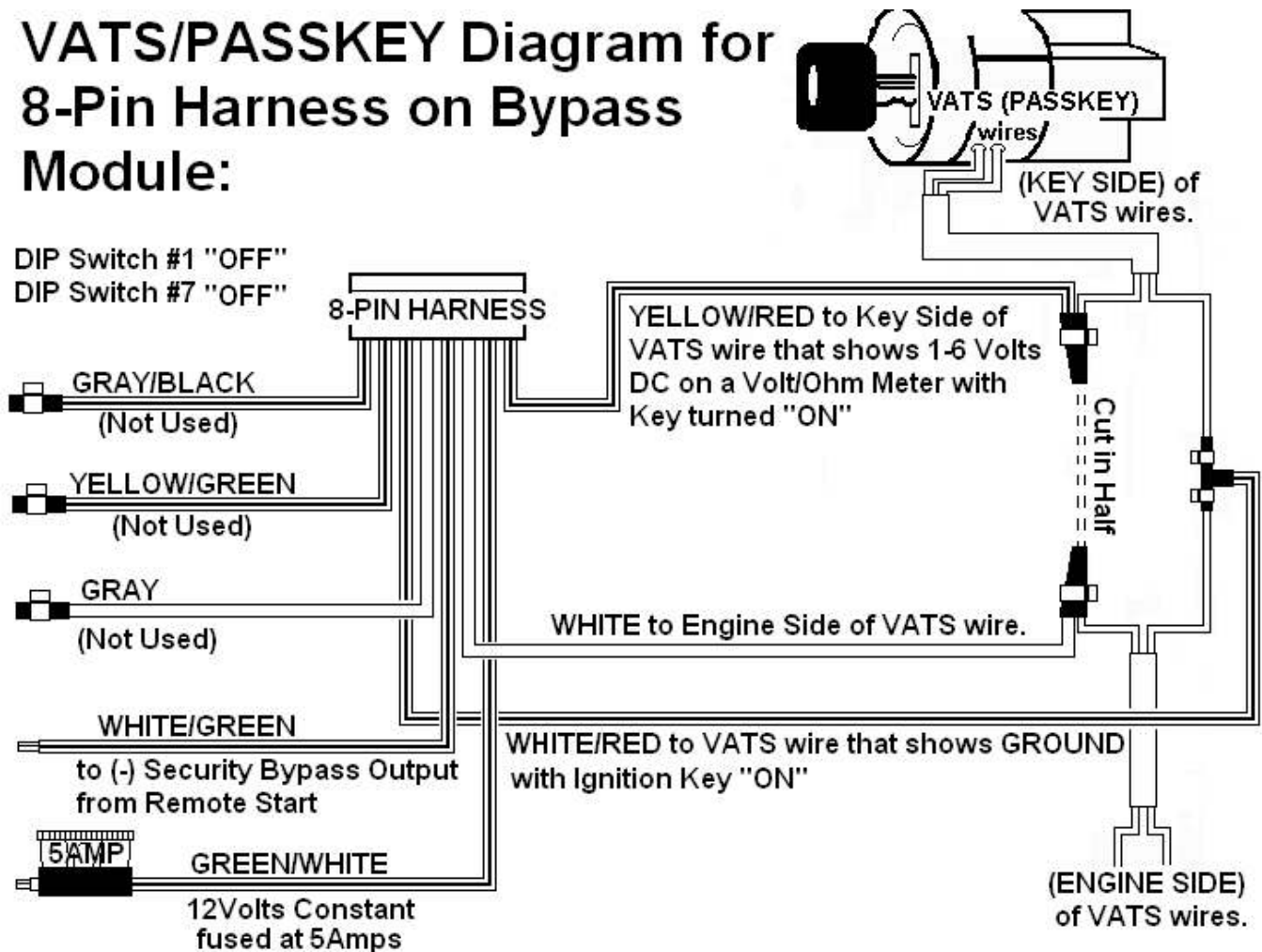

PASSLOCK I:

1. Remove the Lower Steering Column cover on the Steering Column.
2. Locate the (3)Three Small 20 Gauge wires (YELLOW, BLACK and WHITE wires in a GRAY or BLACK Plug) coming out of the Ignition Key Cylinder on the Bottom right hand side of the Steering Column.
3. Cut the **YELLOW** wire in half and strip back both ends. Remove some of the insulation on the **BLACK** wire without cutting the wire and the **WHITE** wire is **not used!!**.
4. Put the vehicle into reverse then turn the ignition key to the Start position and release it to the run position. The vehicle

will not start since you are not in Park – but be sure to have your foot on the brake for safety.

5. With the ignition key still in and turned to the “**RUN**” position, measure the resistance between the **KEY SIDE** of the **YELLOW** wire (this wire will show 1 to 6 V DC on a Volt/Ohm Meter) and the **BLACK** wire (this wire will show GROUND). Make several measurements to verify that you have a consistent resistance. Reverse your test leads around, to verify that you get the same readings. If you get two different readings – we have found that the higher of the two readings is the correct resistance – but check again.
6. When you have identified the correct resistance use the chart on **Page 4** to set the resistance on the bypass module.
7. Locate the **BLACK “Bulb Test”** wire in the Ignition Switch Harness on the **LEFT SIDE** of the Steering Column in cavity “**D**” or “**E**” of the **Black 5-Pin connector (between the Heavy Gauge RED and RED/WHITE wires)**, in the main Ignition Switch Harness. NOTE ** This is a different wire than the **BLACK GROUND** wire mentioned in the above steps.
8. Connect the Bypass module using the diagram below. Be sure to tape up any connections, **DO NOT** leave any exposed wires.
9. When connecting the Anti-Theft Bypass Module to your Remote Starter, you will need to activate this Bypass Module by connecting it in different ways depending on the Remote Starter you have. Attach the **WHITE/GREEN (-)Security Bypass Output** wire from the 8-Pin Harness to: if the unit you are using has a **4-Relay Pack**, tap this **WHITE/GREEN** wire into the Thin **WHITE** wire in the middle of the **3-Pin Plug**, if the Remote Start does not have a 4-Relay Pack and the Relays are On-Board, connect the **WHITE/GREEN** wire to the **WHITE, YELLOW or YELLOW BLACK (-)Negative Ignition Output or (-) Security Bypass Output** wire from the Main Harness on these Remote Starters. On the **DELUXE 200 or DELUXE 500 Models**, connect this **GREEN/WHITE** wire to the **BLUE/BLACK Ignition 3 Control Output wire, the H4/9 wire or H7/1 wire.**

PASSLOCK 1 wire Diagram for 8-Pin Harness on Bypass Module:

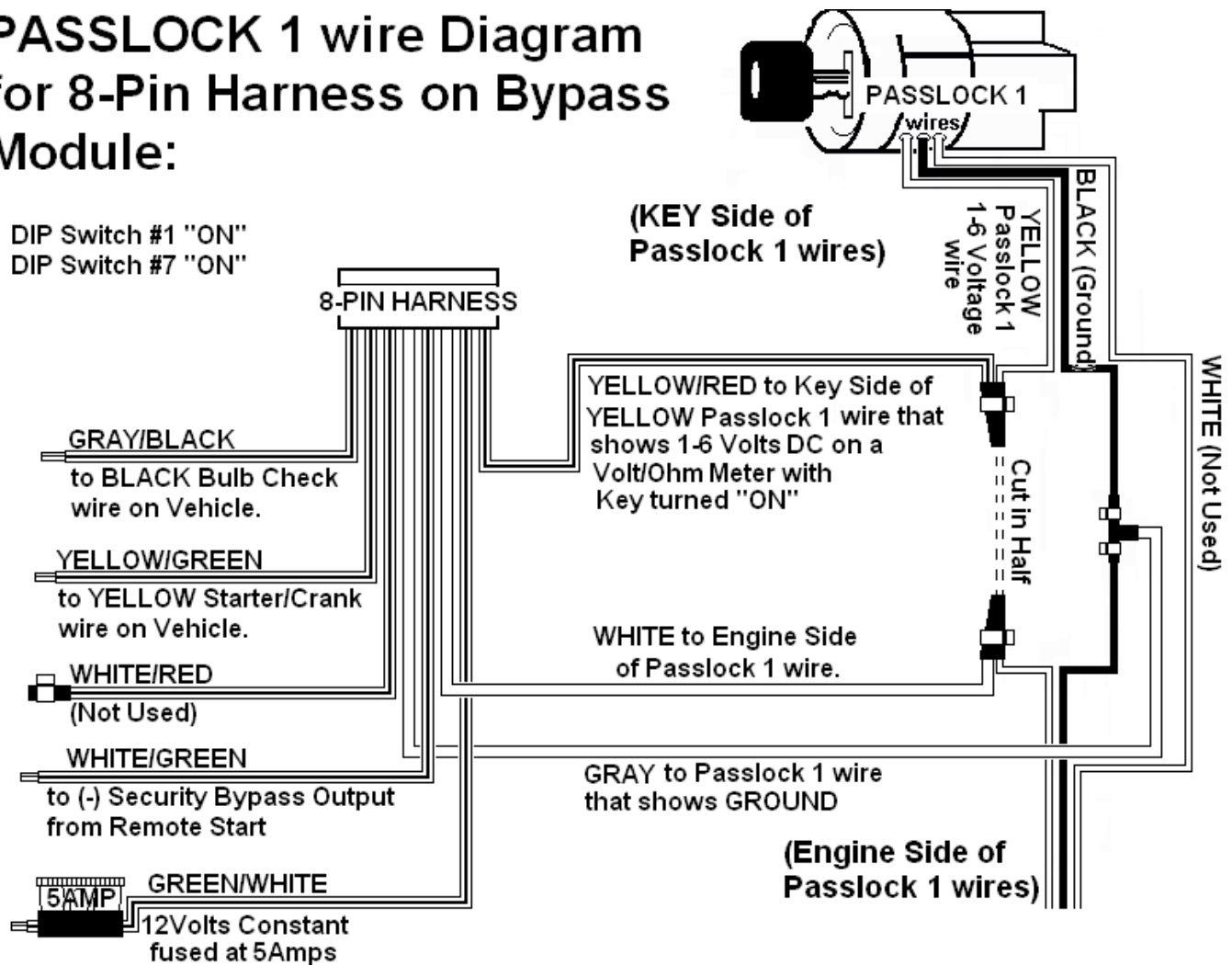

PASSLOCK II:

1. Remove the Lower Steering Column cover on the Steering Column..
2. Locate the (3) **Three Small 20 Gauge wires (YELLOW, ORANGE/BLACK sometimes BLACK and RED/WHITE wires)** coming out of the Ignition Key Cylinder of the Steering Column, these wires are usually wrapped in BLACK friction tape.
3. Cut the **Yellow** wire in half and strip back both ends. Remove the insulation on the **Orange/Black** wire without cutting the wire. The **Red/White** wire is not used.
4. Turn the key to the "Run" position and place the vehicle in Reverse.
5. Turn the key to start, then release the key to the "run" position and measure the resistance between the **KEY SIDE** of the **YELLOW** wire (this wire will show 1 to 6 V DC on a Volt/Ohm Meter) and the **ORANGE/BLACK** wire or **BLACK** wire (this wire will show GROUND) the **RED/WHITE** wire is **NOT USED!!**. (The vehicle will not start since you are not in Park but be sure to have your foot on the brake for safety.) Reverse your test leads around, to verify that you get the same readings. If you get two different readings – we have found that the higher of the two readings is the correct resistance – but check again.
6. When you have identified the correct resistance use the chart on **Page 4** to set the resistance on the bypass module. Locate the closest value that is less than your desired value. Set Dip-Switches 2 through 6 to match the chart on **Page**

4.

7. Put your ohm meter (multi-meter) probes on the (2)Two silver resistance measuring pads through the opening shown in the drawing – making good contact with these (2)Two silver pads on the board. **(See drawing on page 1)**. Or put your (2)Two probes into the (2)Two holes on the bottom of the case making contact with the underside of the silver pads. Either contact point method will work.
8. With the probes held firmly – dial-in the final resistance value needed for your system by turning the screw on the variable resistor on the side of the unit next to the Dip Switches. Turn the screw until the resistance value matches the resistance value of the key.
9. Connect the bypass module using the diagram on the next page. Be sure to tape up any connections **DO NOT** leave any exposed wires.
10. When connecting the Anti-Theft Bypass Module to your Remote Starter, you will need to activate this Bypass Module by connecting it in different ways depending on the Remote Starter you have. Attach the **WHITE/GREEN and GRAY/BLACK (-) Security Bypass Output** wires from the 8-Pin Harness to: if the unit you are using has a **4-Relay Pack**, tap this **WHITE/GREEN and GRAY/BLACK** wires into the Thin **WHITE** wire in the middle of the **3-Pin Plug**, if the Remote Start does not have a 4-Relay Pack and the Relays are On-Board, connect the **WHITE/GREEN and GRAY/BLACK** wires to the **WHITE, YELLOW or YELLOW BLACK (-)Negative Ignition Output or (-) Security Bypass Output** wire from the Main Harness on these Remote Starters. On the **DELUXE 200 or DELUXE 500 Models**, connect this **GREEN/WHITE and GRAY/BLACK** wires to the **BLUE/BLACK Ignition 3 Control Output wire, the H4/9 wire or H7/1 wire**.

PASSLOCK II

PASSLOCK 2 wire Diagram for 8-Pin Harness on Bypass Module:

DIP Switch #1 "OFF"
DIP Switch #7 "OFF"

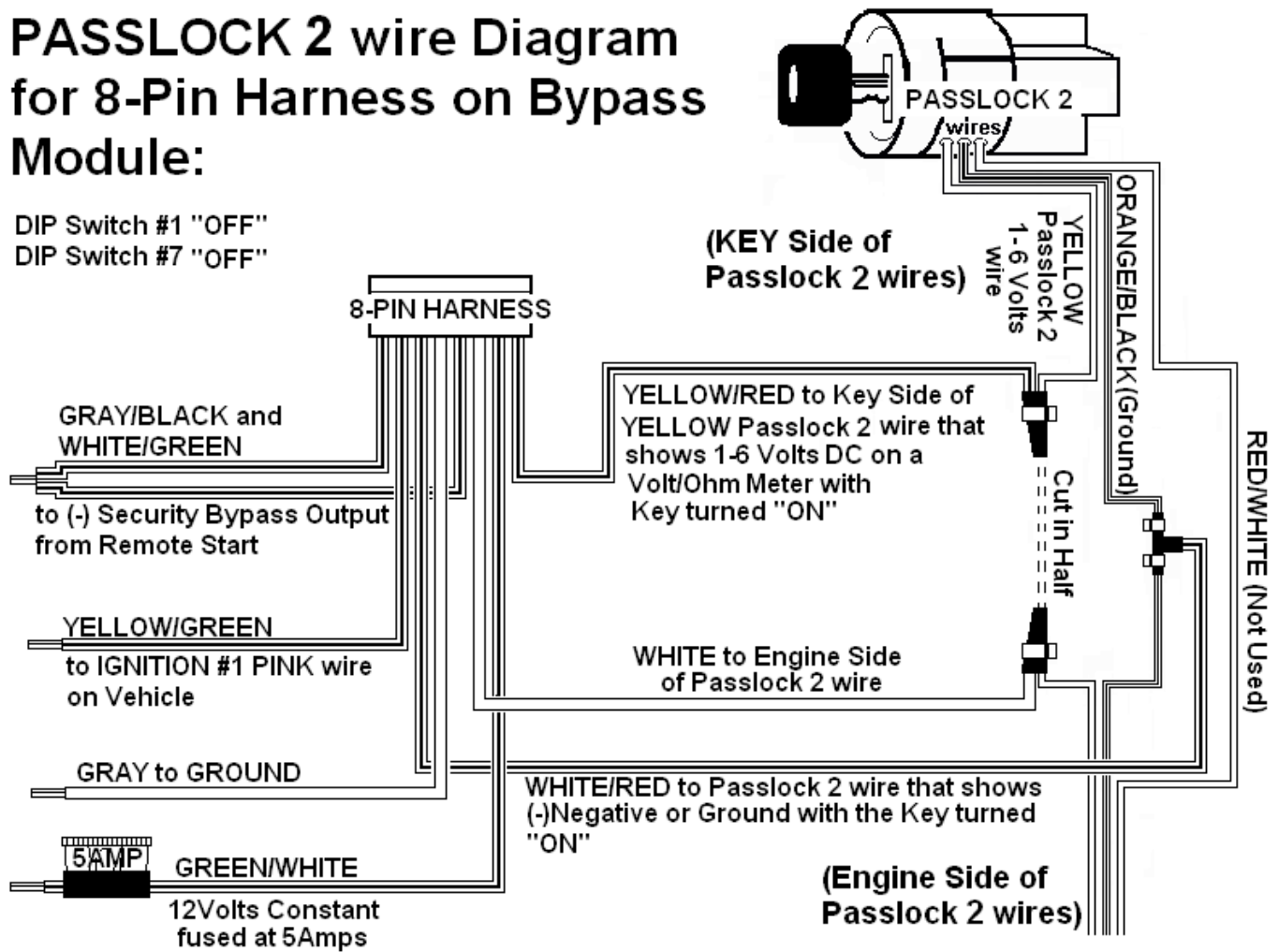

SATURN:

Saturn vehicles (1996-2000) with **Factory Keyless Entry** have a **unique Anti-Theft System**.

1. Locate the **Factory Alarm Module** located behind the Right Rear Quarter Panel (trunk area). Connect the **PINK** and **YELLOW/BLACK** wires of **Connector "J and D"** of the **Factory Anti-Theft Module** as shown.
2. Cut the **PINK wire in half** and connect as shown.
3. Turn all Dip Switches **OFF**.
4. When connecting the Anti-Theft Bypass Module to your Remote Starter, you will need to activate this Bypass Module by connecting it in different ways depending on the Remote Starter you have. Attach the **WHITE/GREEN (-)Security Bypass Output** wire from the 8-Pin Harness to: if the unit you are using has a **4-Relay Pack**, tap this **WHITE/GREEN** wire into the Thin **WHITE** wire in the middle of the **3-Pin Plug**, if the Remote Start does not have a 4-Relay Pack and the Relays are On-Board, connect the **WHITE/GREEN** wire to the **WHITE, YELLOW or YELLOW BLACK (-)Negative Ignition Output** or **(-) Security Bypass Output** wire from the Main Harness on these Remote Starters. On the **DELUXE 200 or DELUXE 500 Models**, connect this **GREEN/WHITE** wire to the **BLUE/BLACK Ignition 3 Control**

Output wire, the H4/9 wire or H7/1 wire.

SATURN ANTI-THEFT BYPASS DIAGRAM 8-Pin Harness on Bypass

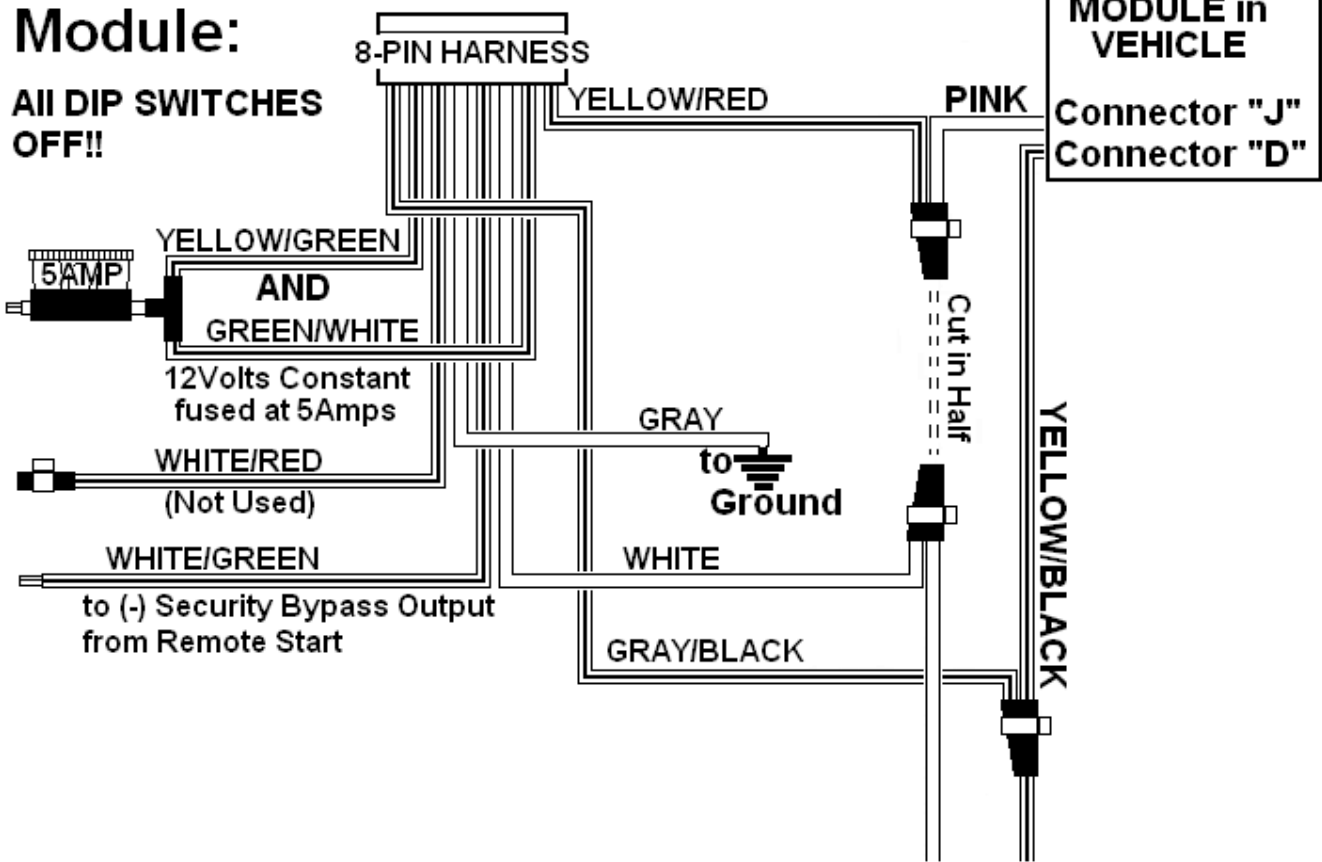

TRANSPONDER / GM PASSLOCK III:

PATS, 'Smart Key', GM PASSLOCK III, Sentry Key, Securi-Lock and others, are all TRANSPONDER SYSTEMS:

Note: For this type of Anti-Theft System – you must sacrifice one of your spare Programmed Transponder Ignition Keys that STARTS this vehicle. This extra **TRANSPONDER Key** will be **PLACED INSIDE the Anti-Theft Bypass Module**, your dealership can program an extra spare key, you can get one from a local Lock Smith or purchase one through JBS Technologies, but make sure they program all keys to the vehicle since learning just one transponder could erase all other key transponders (including the key used for the Bypass Module).

1. Again, an extra **Programmed Transponder Ignition Key** that starts the vehicle, will need to be placed inside the Anti-Theft Bypass Module.
2. Pull apart the case and place the **Programmed TRANSPONDER KEY**, inside the **10-Wire Loop** on the circuit board. Transponder Keys are directional and must be placed along the same direction that the key would lay in the Ignition

Switch. Use the double stick foam tape provided, one layer on the circuit board and then the Transponder Key, and finally the second double-stick foam tape layer on top of it to hold key securely in place, See Below:

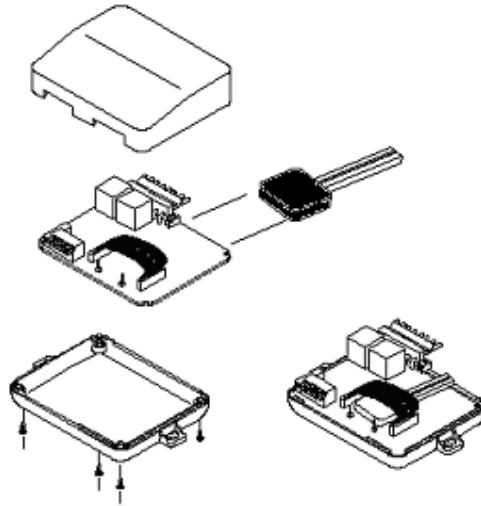

3. The **TRANSPONDER LOOP Antenna** must be routed through the Steering Column and up towards and then around the **Ignition Key Cylinder** and needs to be positioned so that there are at least (2)Two turns (the more turns the better chance the signal will be Received by the Factory Receiver Antenna) around the Ignition Key Cylinder as shown below. Transponder systems often have a **BLACK PLASTIC RING** around the Ignition Lock Switch. This is the vehicle's Transponder Pick-up or Receiver Ring Antenna. It is important that the **at Least (2) Two loops** of the Bypass Module's **TRANSPONDER LOOP ANTENNA** be mounted on or as close to the Factory Receiver Ring (BLACK PLASTIC RING) as possible. Slide the tube up towards the ignition switch to tighten up the loops of wire. Tape in place to hold. Plug the 2-Pin Connector of the Transponder Loop Antenna into the Universal Bypass Module.

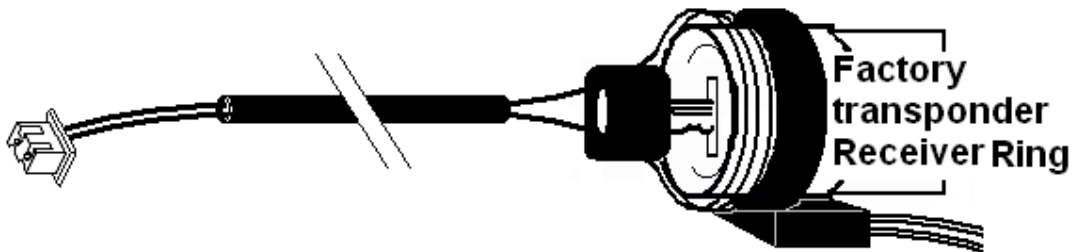

4. Now start the vehicle with the Remote Starter. If the vehicle starts and runs for at least 30 seconds the Transponder Bypass Module, the placement of the Key inside the Bypass Module and the Transponder Loop Antenna are installed correct.

Note: If the vehicle does not start with the Remote Starter or runs for approx 5 seconds and shuts down, try adjusting or changing the position of the Transponder Key in the Bypass Module or adjusting the position of the (2)Two Loop Antenna wire around the Transponder Pick-up/Receiver Antenna as mentioned above.

5. When connecting the Anti-Theft Bypass Module to your Remote Starter, you will need to activate this Bypass Module by connecting it in different ways depending on the Remote Starter you have. Attach the **WHITE/GREEN (-)Security Bypass Output** wire from the 8-Pin Harness to: if the unit you are using has a **4-Relay Pack**, tap this **WHITE/GREEN** wire into the Thin **WHITE** wire in the middle of the **3-Pin Plug**, if the Remote Start does not have a 4-Relay Pack and the Relays are On-Board, connect the **WHITE/GREEN** wire to the **WHITE, YELLOW or YELLOW BLACK (-)Negative Ignition Output**

or (-) Security Bypass Output wire from the Main Harness on these Remote Starters. On the DELUXE 200 or DELUXE 500 Models, connect this GREEN/WHITE wire to the BLUE/BLACK Ignition 3 Control Output wire, the H4/9 wire or H7/1 wire.

TRANSPONDER Diagram for 8-Pin Harness on Bypass Module:

All DIP SWITCHES OFF!!

