

# CHRYSLERS REVERSE POLARITY TRUNK POP

## DIAGRAM: Using a (-)NEGATIVE Trunk Pop Output

RS-102/112/122, RS-202, RS-602E, DELUXE 12/22,  
DELUXE 62, 1402, 5002, 6002, and 7002E Units

### Requires (1) of part # 775

Connect the WHITE and the YELLOW wire from the #775 relay to 12 volts CONSTANT fused at 10amps.

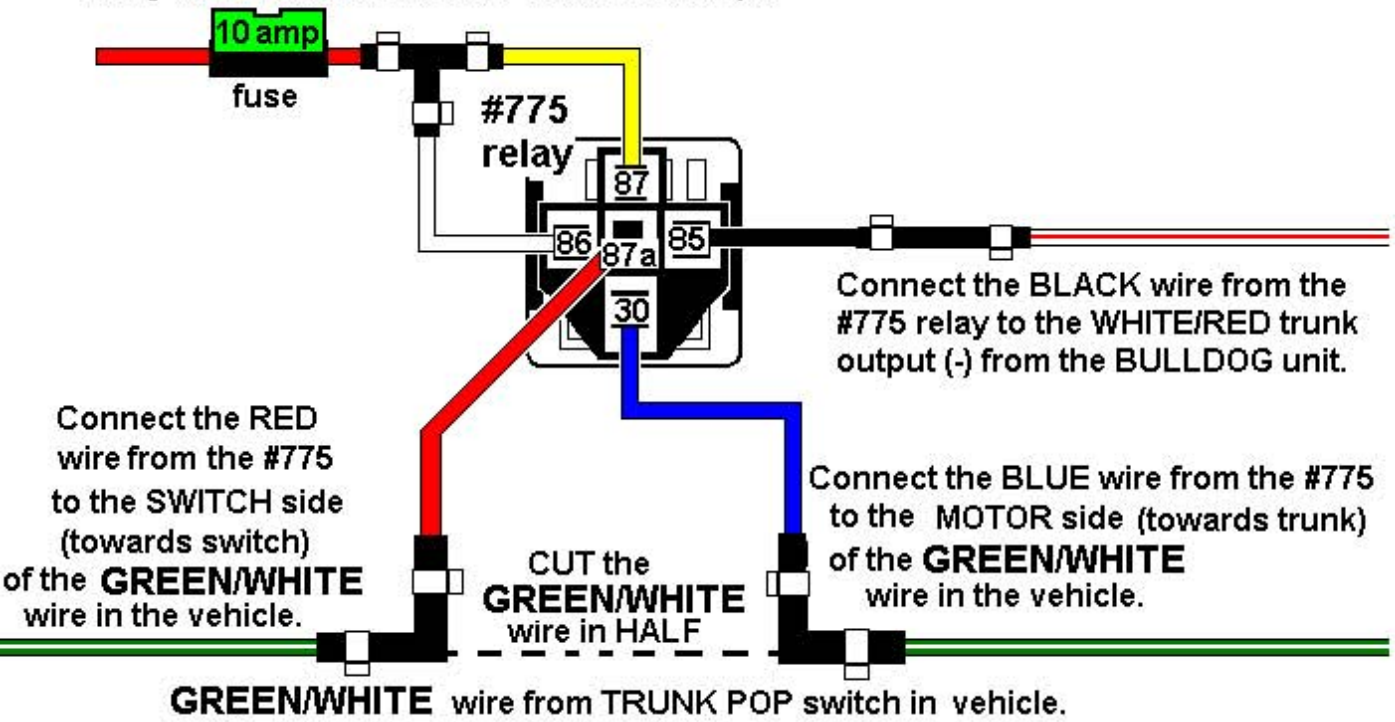

## Using a (+) POSITIVE Trunk Pop Output:

RS-1100(114), 1200, and 1300E

### Requires (1) of part # 775

